



REVOL Class A/B 4 Channel Amplifier

Phoenix Gold
Product Manual

V754

4 Channel Power Amplifier

Amplificateurs à 4 canaux

12dB per octave Variable Lowpass Crossovers

Croisements passe-bas variables 12dB

3 Position Configuration Switch LP/Bypass/HP (LowPass, By-Pass, HighPass)

Commutateur de configuration LP/Bypass/HP (passe-bas, contournement, passe-haut)

Auxiliary Outputs

Sorties auxiliaires

Speaker Level Inputs

Entrées de niveau d'amplificateur

Remote Monitoring Display (RMD) Port

Port d'affichage de contrôle à distance (RMD)

Extruded Aluminum Heat Sink

Drain thermique en aluminium extrudé



Congratulations on your purchase of high quality Phoenix Gold audio electronics. At Phoenix Gold our highest concern is musical reproduction. We appreciate that you chose our product. Through years of engineering expertise and critical testing procedures, we have created a wide range of products to give your system all the clarity and richness you deserve.

Great product and competent installations are only one piece of the puzzle when it comes to your system. Make sure that your install is using only the best installation accessories. Phoenix Gold manufactures everything from RCA cables and speaker wire to power/ground cable and battery connectors. With proper installation and accessories your system will last for years and perform to peak audio standards.

Please read your warranty and retain your receipt and original carton for possible future use.

For more information about Phoenix Gold electronics, speakers and accessories please visit



Ryval® Amplifiers

4 CHANNEL POWER AMP OWNERS MANUAL

Operational Details

1. **STATUS LED**
Green- Amplifier is powered "ON"
2. **PROTECT LED**
Red- If the internal heatsink reaches 80 degrees Celsius the amplifier shuts down until the internal temperature falls below 75 degrees. It also lights if a direct short is present on the speaker outputs. If this occurs, check for shorted speakers and cycle power to resume operation.
3. **REMOTE TURN-ON TERMINAL**
Connect to a switched 12 Vdc source such as the headunit's "remote" or power antenna wire.
4. **B- TERMINAL (CHASSIS GROUND)**
Connect to a clean, solid chassis ground. Remove all paint and dirt from the chassis connection point. Minimum cable size is 8 gauge. Keep the cable as short as possible.
5. **B+ TERMINAL (BATTERY POSITIVE)**
Connect directly to the positive battery terminal. Minimum cable size is 8 gauge. Remember to properly fuse this cable within 18 inches of the positive battery terminal.
6. **SPEAKER OUTPUTS**
Used to connect the amplifier to speakers. Use the left (+) and right (-) terminals for bridged mode. Minimum stereo speaker cable size is 16 gauge (PG # SS162 or QS162). Use 12 gauge for bridged operation (PG # SS122 or QS122). Minimum impedance is 4 ohm bridged or 2 ohm stereo.
7. **FUSES**
Used to protect the amplifier. If replacement is necessary, use the same size and type indicated on the endpanel. **Never use a fuse with a higher amp rating.**
8. **REMOTE VOLTAGE DISPLAY INPUT (RMD)**
Connect the optional RMD Voltage Display to this jack.
9. **CROSSOVER CONFIG SWITCH**
This switch controls the type of signal that reaches the speaker outputs. For a 100Hz highpass signal, set the switch to "100Hz HP". For continuously variable lowpass signal set the switch to "VAR LP". For a full range signal set the switch to "BY".
10. **LP FREQ CONTROL**
Adjusts the lowpass crossover point for the speaker outputs. The crossover frequency is adjustable from 40 to 400Hz with a 12dB per octave lowpass slope.
11. **RCA INPUT**
Connect preamp signal cables from the head unit to these terminals. To maximize noise rejection, we recommend using Genuine Phoenix Gold RCA interconnects.
12. **INPUT SELECT**
When set to "FRONT" the front inputs will provide signal for the entire amplifier. When set to "FRONT+REAR" both the front and rear inputs will accept signal separately allowing the use of a headunit fader.
13. **AUX OUT**
Provides a full range signal for an additional amplifier.
14. **SENS CONTROL**
This control is used to reach maximum amplifier power with a wide variety of headunits. The amplifier is more sensitive to input signal when set to 0.1 and less sensitive when set to 8; turning the control clockwise will increase signal speaker output volume.



15. SPEAKER LEVEL INPUT

Connect headunits speaker level outputs to these terminals using the supplied connector. The speaker level input accepts a wide voltage range (200mV to 20Vdc) used with most headunit and OEM systems.

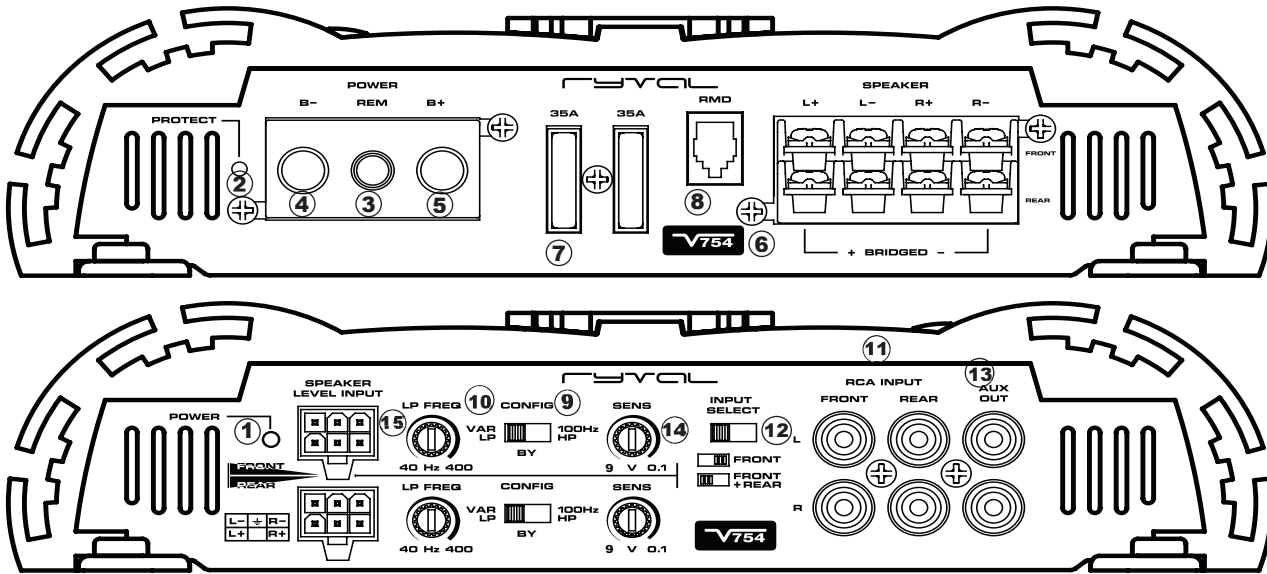

Ryval Series
V754

Class A/B 4 Channel Amplifier

FIG 1.
Front/Rear Stereo High Pass System
Lowest recommended load:
2 Ohm stereo

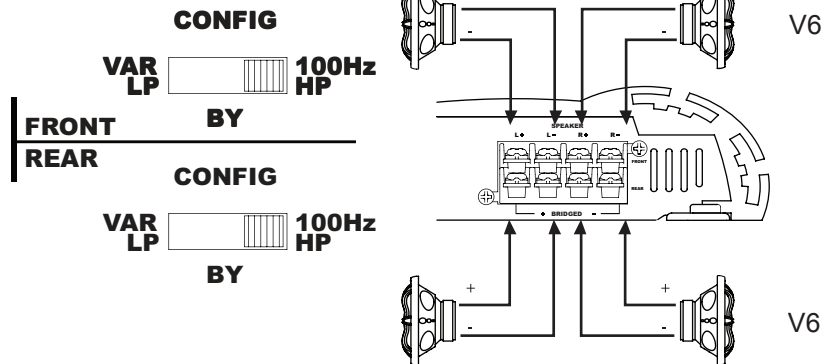
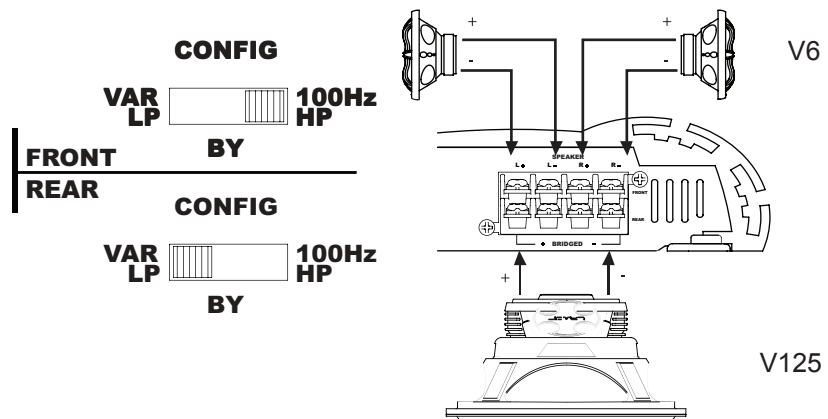

FIG 2.
Front/Rear Stereo Low Pass System
Lowest recommended load:
2 Ohm stereo
4 Ohm bridged



Ryval® Amplifiers

4 CHANNEL POWER AMP OWNERS MANUAL INSTALLATION

Note: Verify that your vehicle does not have a positive ground electrical system, this is very rare. A positive ground system is the reverse of most standard vehicles in that the + battery terminal is connected to the vehicle chassis and is typically found in some older European vehicles. If you have any questions do not proceed until you have verified this. If it is a positive ground electrical system please contact your dealer for assistance.

Caution: Please follow all the installation recommendations and instructions in this manual. Installation in any manner not outlined in the manual will void your warranty and may possibly cause damage to the vehicle and/or the amplifier.

Warning: The battery ground should remain DISCONNECTED at all stages of installation.

LOCATION/MOUNTING

When selecting a location to mount your amplifier, please keep in mind that electronics are sensitive to vibration, moisture, and heat. Make sure the amplifier is mounted in an area with ample ventilation and is not exposed to moisture or external heat.

For proper cooling, it is recommended to mount the amplifier horizontal or vertical but not upside-down. Automobiles have a certain level of normal vibration and we have designed the product with this in mind, but excessive vibration may cause damage over time. Using the amplifier for a template, mark the mounting holes in your selected area while following the preceding guidelines. Verify that you are not going to damage sensitive vehicle systems by drilling where you have selected (look for the gas tank, wires, etc...).

Remove the amplifier and pre-drill the locations for the screws/bolts that you have selected that fit the amplifier and your new installation purposes. Permanently mount the amplifier to the selected location.

(Figure 3. shows a typical system configuration).

Note: It is best to mount the amplifier to some form of insulating surface, such as MDF, so that the chassis of the amplifier does not come in contact with the vehicle chassis (if a single screw makes contact with both the amplifier and vehicle chassis, it is not insulated). This will reduce the possibility of any ground related noises and will shield minor amounts of radiated noises.

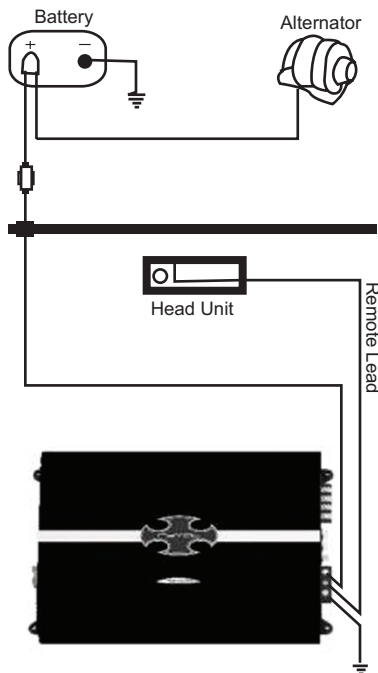

FIG 3.



Installation Tip!

Real Power creates Heat!

Ryval amplifiers are designed to give you every bit of electrical energy possible as output power. Be sure to install the amplifier in an area that has good airflow to prevent un-intentional thermal shut down.

Installation Tip!

System Tuning

Warning! Practice "Safe Sound" and Use Hearing Protection When Listening To Extreme Sound Pressure Levels.

1. Set the CONFIG switch according to your system setup.
2. Set the amplifier SENS Control to minimum (full counterclockwise).
3. If using the amplifier in Lowpass mode, set the LP FREQ control to the 10 O'clock position. This is a starting point for the crossover; you may need to fine tune this setting later.
4. Turn the headunit on with the volume set to minimum.
5. Set the headunit's tone controls, balance and fader to the center (flat) position and turn off any loudness features or other processing effects.
6. Play a CD that represents what type of music you usually listen to. Set the volume control of the head unit up to 90% of total volume or until you hear distortion if you are using the headunit's internal amplifier.
7. Increase (turn clockwise) the SENS Control for the amplifier until you hear distortion then slightly decrease the sensitivity control until the distortion is not audible. The volume level should still be very loud, but free from nearly all distortion.
8. With all speakers in the car playing, listen to the CD at this same high volume level and make sure all channels blend properly. For example, if the front speakers overpower the subwoofer, then slowly balance the system so all channels reach maximum output without distortion at this volume level.
9. The volume level set in step 6 will be your maximum volume level for your system. If you exceed this level, the onset of distortion will become very noticeable.

Specifications

V754 A/B 4 Channel Amplifiers

V754

Maximum Output Power

Into 4 Ohms Stereo.....	150 X 4
Into 2 Ohms Stereo.....	250 X 4
Into 4 Ohms Bridged.....	500 X 2

Continuous Output Power (14.4VDC 1% THD+N CEA2006 METHOD)

Into 4 Ohms Stereo.....	75 X 4
Into 2 Ohms Stereo.....	120 X 4
Into 4 Ohms Bridged.....	250 X 2

Recommended Fuse Size.....2 X 35 AMP ATO

Chassis Dimensions.....13.15" X 9.30" X 2.25"
(334 X 236 X 55mm)

Frequency Response.....20Hz – 20 kHz

Signal to Noise Ratio (1% THD+N).....>100dBA

RCA Signal Input Sensitivity.....100mV – 9V (RCA Inputs)

Speaker Level Input Sensitivity.....200mV – 18V (High Level Inputs)

DC Input Range.....9V – 18V

Typical Current Draw at Idle.....1 A

Crossover Slope.....12dB/Octave

Crossover Range (Lowpass).....45Hz – 400Hz

Minimum Load Stability.....2 Ohm Stereo/4 Ohm Bridged



TROUBLE-SHOOTING

SYMPTOM: POSSIBLE CAUSE

No power: Check voltage at amplifier with a DMM (volt meter), B+ and REM (with source unit on) the voltage should register between 12.2V-14.6V when using the attached ground lead of the amplifier. Check fuse at amplifier and at the battery. Use a meter to verify connection from one end of the fuse to the other, breaks may not always be visible. If fuse is blown, check the power wire and also the amplifier for a short. If the short is in the power wire, repair it. If the short is in the amplifier itself, see your Phoenix Gold dealer. If no short is present replace the fuse.

Power without sound: Turn the amplifier off and check all input and output signal cables and power connections. Check the speakers for shorts with a DMM (volt meter) or by connecting them to another audio source. After making sure everything is correct, turn the amplifier on again.

Power without sound and status LED is lit red: A continuous red light of the power indicator signals a high internal operating temperature, which results in the amplifier switching off temporarily. When the amplifier cools down to a safe level, the amp will automatically restart. The continuous red light of the power indicator can also indicate a shorted speaker lead or battery voltage that is either too high or too low for proper operation. Cycle power to reset this condition.

No sound from one side: Check balance control. Check speaker connections. Check signal input connection.

Very low output: Check your source unit's fader control, or the amplifier's Input Sensitivity Level.

Frequent automatic amplifier shut down: This indicates that the amplifier is operating at a continually undesirable high internal temperature. High operating temperature can be caused by inadequate ventilation: Refer to the sub-section titled LOCATION for better amplifier location. High operating temperature can also be caused by an excessively low impedance load. For instance below 2 ohms stereo or 4 ohms bridged. Check for bad speakers or bad passive crossover components. If all else fails, try rewiring the entire system. High operating temperature can be caused by an incorrect input sensitivity level, refer to sub-section titled INPUT SENSITIVITY ADJUSTMENT.

"Motor Boating" - the power indicator going off repeatedly when the audio system is on: Check the amplifier's connection to the battery. Check battery voltage. If low, recharge or replace battery. Check all ground connections.

Whining noise when engine is running: Reroute power cable from battery to source unit directly (include fuse), bypassing the battery terminal in the fuse box. Check power connections to be sure they are clean. Check the battery ground making sure the battery terminals and chassis ground are clean. Run a ground wire from the source unit to the ground point of the amplifier and remove old source ground.

CAUTION: Do not disconnect the Power Amplifier's ground when the system is on. This could damage the amplifier.



Ryval Amplifiers

4 CHANNEL POWER AMP OWNERS MANUAL

WARRANTY

LIMITED WARRANTY ELECTRONICS (USA)

Phoenix Gold warrants this product to be free of defects in materials and workmanship for a period of one (1) year from the original date of purchase. This warranty is extended to two (2) years from the original date of purchase if product is installed by an authorized Phoenix Gold reseller. The limited warranty period for factory refurbished products expires after ninety (90) days from the original date of purchase. This limited warranty applies only to purchases from authorized Phoenix Gold resellers in the United States, and is extended only to the original purchaser of this product. (See paragraph below for information regarding purchases made in other countries.)

This warranty is not transferable from the original purchaser to any other party. If service is necessary under this warranty Phoenix Gold will (at its discretion), repair or replace the defective product with new or remanufactured product at no charge. Damage caused by the following is not covered under warranty: accident, misuse, abuse, product modification or neglect, failure to follow installation instructions, unauthorized repair attempts, misrepresentations by the seller. This warranty does not cover incidental or consequential damages and does not cover the cost of removing or reinstalling the unit(s). Cosmetic damage due to accident or normal wear and tear is not covered under warranty.

Any applicable implied warranties are limited in duration to the period of the express warranty as provided herein beginning with the date of the original purchase at retail, and no warranties, whether express or implied, shall apply to this product thereafter. Some states do not allow limitations on implied warranties, therefore these exclusions may not apply to you. This warranty gives you specific legal rights, and you may also have other rights which vary from state to state.

WARRANTY IS VOID IF THE PRODUCT'S SERIAL NUMBER HAS BEEN REMOVED OR DEFACED.

IF YOU NEED SERVICE ON YOUR PHOENIX GOLD PRODUCT:

Phoenix Gold encourages product owners to first contact their original Phoenix Gold reseller to determine whether the issue can be resolved without sending the product back to Phoenix Gold.

If a return is necessary, the reseller will contact Phoenix Gold to obtain authorization for the return. All returns require a Return Authorization number from Phoenix Gold before shipping the product to Phoenix Gold's service facility. If a product owner is unable to return a product to the original reseller, the owner can contact Phoenix Gold directly to obtain a Return Authorization number. Units returned to Phoenix Gold without an RA number may be subject to refusal or delays.

All warranty returns should be sent to Phoenix Gold's Product Service facility freight-prepaid and must be accompanied by proof of purchase (a copy of the original sales receipt).

Non-defective items received may be returned freight-collect. Customer is responsible for shipping charges and insurance when sending the product to Phoenix Gold. Freight damage on returns is not covered under warranty.

FOR SERVICE INFORMATION IN THE U.S.A. PLEASE CALL:

Phoenix Gold Customer Service: (503) 286-9300 or (800) 950-1449 during normal business hours (8:30 AM – 5:00 PM Pacific Standard Time)

INTERNATIONAL WARRANTIES:

Products purchased outside the United States of America are covered only by that country's Authorized Phoenix Gold reseller and not by Phoenix Gold International, Inc. Consumers needing service or warranty information for these products must contact that country's reseller for information.

Use the following area record basic information about your purchase.

Model Number _____
Serial Number (if available) _____
Date of Purchase _____
Store/Reseller Purchased from _____



Ryval® Amplifiers

4 CHANNEL POWER AMP OWNERS MANUAL

GARANTIE

GARANTIE LIMITÉE SUR LES ARTICLES ÉLECTRONIQUES (É.-U)

Phoenix Gold garantit que ce produit est exempt de défaut matériel et de main d'oeuvre pour une période d'une (1) année à compter de la date d'achat originale. Cette garantie est prolongée de deux (2) années à compter de la date d'achat originale à la condition que le produit soit installé par un revendeur autorisé Phoenix Gold. La période de garantie limitée pour les produits remis à neuf en usine expire après quatre-vingt-dix (90) jours de la date d'achat originale. Cette garantie limitée n'est valable que pour les achats effectués auprès de revendeurs autorisés Phoenix Gold aux États-Unis et ne s'applique qu'à l'acheteur original de ce produit. (Voir le paragraphe ci-dessous pour des renseignements concernant les achats effectués dans d'autres pays.)

Cette garantie n'est pas transférable de l'acheteur original à toute autre personne. Si une réparation s'avère nécessaire en vertu de cette garantie, Phoenix Gold fera réparer ou remplacera (à sa discrétion) sans frais le produit défectueux avec un nouveau ou un produit remis à neuf. Les dommages découlant des situations suivantes ne sont pas couverts par cette garantie : accident, mauvais usage, abus, modification du produit ou négligence, omission de suivre les directives d'installation, tentatives non autorisées de le réparer, assertions inexactes du vendeur. Cette garantie ne couvre pas les dommages occasionnels ou corrélatifs ni le coût d'enlèvement ou de réinstallation du/des produit/s. Les dommages esthétiques découlant d'un accident ou d'une usure normale ne sont pas couverts en vertu de cette garantie.

La durée de toutes les garanties implicites applicables est limitée à la période de la garantie expresse énoncée aux présentes, et ce, à compter de la date de l'achat original au détail, et aucune autre garantie, exprès ou implicite, ne s'appliquera à ce produit par la suite. Certains États ou certaines provinces n'autorisent pas de limites aux garanties implicites. Par conséquent, ces exclusions peuvent ne pas s'appliquer pour vous. Cette garantie vous accorde des droits légaux spécifiques et vous pouvez avoir également d'autres droits qui varient d'un/e État/province à un/e autre.

CETTE GARANTIE SERA NULLE ET SANS EFFET SI LE NUMÉRO DE SÉRIE DE CE PRODUIT A ÉTÉ ENLEVÉ OU EFFACÉ.

SI VOTRE PRODUIT PHOENIX GOLD REQUIERT UNE RÉPARATION :

Phoenix Gold invite les propriétaires de ce produit à communiquer en premier avec leur revendeur Phoenix Gold original afin d'établir si le problème peut être résolu avant de le retourner à Phoenix Gold.

S'il est nécessaire de le retourner, le revendeur communiquera avec Phoenix Gold pour obtenir une autorisation. Toutes les marchandises retournées doivent avoir un numéro d'autorisation de Phoenix Gold avant d'être expédiées au centre de service de la compagnie. Le propriétaire d'un produit dans l'impossibilité de retourner celui-ci au revendeur original devra communiquer directement avec Phoenix Gold pour obtenir un numéro d'autorisation. Les articles retournés à Phoenix Gold sans un numéro d'autorisation risquent d'être refusés ou retardés.

Tous les retours sous garantie doivent être expédiés prépayés au centre de service de Phoenix Gold et ils doivent être accompagnés d'une preuve d'achat (un exemplaire du reçu de caisse original).

Les articles reçus et non défectueux seront retournés et le fret payable à destination. Les frais d'expédition et d'assurance sont à la charge du client lorsque le produit est expédié à Phoenix Gold. Les dommages causés au produit lors du transport ne sont pas couverts par cette garantie.

POUR TOUTE INFORMATION SUR LES SERVICES AUX ÉTATS-UNIS, VEUILLEZ APPELER :

Service à la clientèle Phoenix Gold : (503) 286-9300 ou (800) 950-1449 lors des heures normales de bureau (8 h 30 à 17 h - Heure normale du Pacifique)

GARANTIES INTERNATIONALES

Les produits achetés à l'extérieur des États-Unis d'Amérique sont uniquement couverts par le revendeur autorisé Phoenix Gold du pays et non pas par Phoenix Gold International, Inc. Les clients qui requièrent des services de réparation ou de l'information sur la garantie de ces produits doivent communiquer avec le revendeur de leur pays.