



# TantrumX High Excursion Subwoofers

## SPECIFICATIONS

### TantrumX Subwoofers

	10/10d	12/12d
Mounting Depth	.5 26/32 in	.6 9/32 in
Mounting Diameter	.9 7/32 in	.11 9/32 in
Overall Diameter	.10 13/32 in	.12 29/32 in
Peak Power Handling	.550 Watts	.600 Watts
RMS Power Handling	.300 Watts	.350 Watts

### TantrumX 10

#### T/S Parameters

Fs	.29.9 Hz
Re	.3.4 Ohms
Qms	.5.38
Qes	.0.374
Qts	.0.350
Vas	.32.97 liters
Mms	.143.93 grams
Cms	.205 uM/Newton
BL	.15.53 Tesla-M
SPL (1W/1M)	.85 dB
Sd	.337 sq cm
Xmax (field)	.32mm p-p

### TantrumX 10d

#### T/S Parameters

Fs	.31.9 Hz
Re	.7.28 Ohms
Qms	.4.26
Qes	.0.48
Qts	.0.431
Vas	.27.66 liters
Mms	.144.26 grams
Cms	.163 uM/Newton
BL	.14.7 Tesla-M
SPL (1W/1M)	.85 dB
Sd	.337 sq cm
Xmax (field)	.32mm p-p

### TantrumX 12

#### T/S Parameters

Fs	.30.26 Hz
Re	.3.4 Ohms
Qms	.4.32
Qes	.0.515
Qts	.0.46
Vas	.65.25 liters
Mms	.169.71 grams
Cms	.163 uM/Newton
BL	.14.76 Tesla-M
SPL (1W/1M)	.87 dB
Sd	.531 sq cm
Xmax (field)	.32mm p-p

### TantrumX 12d

#### T/S Parameters

Fs	.33.8 Hz
Re	.7.24 Ohms
Qms	.3.71
Qes	.0.58
Qts	.0.5
Vas	.56.84 liters
Mms	.160 grams
Cms	.142 uM/Newton
BL	.20.51 Tesla-M
SPL (1W/1M)	.87 dB
Sd	.531 sq cm
Xmax (field)	.32mm p-p

Due to ongoing to research, specifications are subject to change.

## LIMITED WARRANTY

Phoenix Gold International, Inc. (or "Phoenix Gold") warrants its products against defects in materials and workmanship for a limited period of time. For a period of 90 days from date of original purchase, we will repair or replace the product, at our option, without charge for parts and labor. Customer must pay all parts and labor charges after the limited warranty period expires. The limited warranty period for factory refurbished products expires after ninety (90) days from date of original purchase. The warranty is extended to 2 years from date of purchase if installed by an authorized Phoenix Gold dealer. This limited warranty applies only to purchases from authorized Phoenix Gold Electronics/Speaker retailers.

This limited warranty is extended only to the original purchaser and is valid only to consumers in the United States. Consumers are required to provide a copy of the original sales invoice from an authorized Phoenix Gold dealer when making a claim against this limited warranty. This limited warranty only covers failures due to defects in materials or workmanship that occur during normal use. It does not cover failures resulting from accident, misuse, abuse, neglect, mishandling, misapplication, alteration, faulty installation, modification, service by anyone other than Phoenix Gold, or damage that is attributable to Acts of God. It does not cover costs of transportation to Phoenix Gold or damage in transit.

This warranty will become void if the serial number identification has been wholly or partially removed, altered or erased. Repair or replacement under the terms of this warranty does not extend the terms of this warranty. Should a product prove to be defective in workmanship or material, the consumer's sole remedies will be repair or replacement as provided under the terms of this warranty. Under no circumstances shall Phoenix Gold be liable for loss or damage, direct, consequential or incidental, arising out of the use of or inability to use the product. There are no express warranties other than described above.

# PHOENIX GOLD

PHOENIX GOLD INTERNATIONAL

9300 North Decatur  
 Portland, OR 97203  
 Tel: 503.286.9300  
 Fax: 503.978.3380  
 www.phoenixgold.com

# PHOENIX GOLD



## TantrumX 10 and 12 inch High Excursion Subwoofers

features • For complete manuals, technical tips, FAQ's, system diagrams and new product information visit us @

- Custom Tooled Injection Molded Tantrum Heat-Sink Dust Cap
- Integrated Ultra-Bright Blue LED Power Indicator
- Injection Molded Grained Polypropylene Cone
- Four Layer 2 Inch Voice Coil
- High Temperature Aluminum Former
- Injection Molded Rubber Mounting Gasket
- Heavy Duty Cast Aluminum Basket
- Injection Molded Rubber Motor Housing
- Five-Way Nickel Plated Binding Posts
- Custom Tooled Computer Optimized Linear Spider
- Robust 65 Ounce Y30 Grade Computer Optimized Motor Structure

www.phoenixgold.com

## Speaker Anatomy

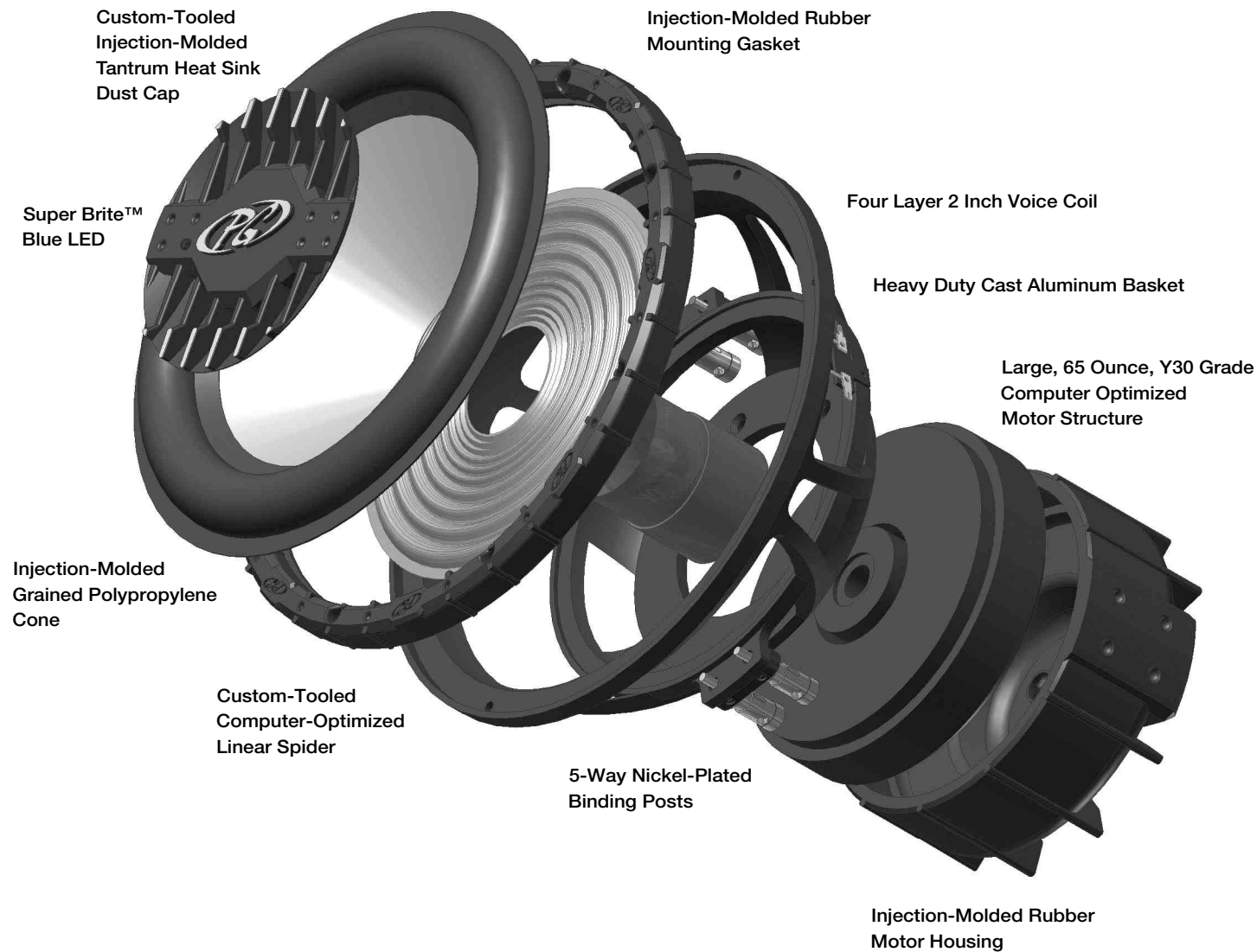

## Speaker Design

The **TantrumX** subwoofer was developed from the ground up to compliment the amazing performance of our Tantrum Series amplifiers. Utilizing cutting edge design techniques, we can deliver a woofer that has an impressive peak to peak linear field excursion of up to 32mm. The injection-molded Tantrum heat sink dust cap in conjunction with the injection-molded polypropylene

cone provides exceptional musicality at very high drive levels. All of the motor and suspension parts have been computer optimized to provide symmetrical driving force in both directions. This translates into very low distortion and exceptional output even as your amplifier is running out of steam.



## Enclosure Information

The **TantrumX** subwoofers are over-engineered and overbuilt in virtually every way conceivable. It's very important that the enclosure is built to these same exacting standards. The enclosure must be made of .75 inch MDF. Screws or air staples are excellent construction fasteners when used with a strong bonding "yellow" wood working glue that can fill joint gaps. Be sure that the enclosure panels are airtight at all joining seams. Lining the walls with a polyester matting 1 to 3 inches thick is sufficient.

Your PG dealer has extensive knowledge, tools and the experience needed for the design and construction

necessary for your **TantrumX** subwoofer application. We also recommend you consult with your dealer for specific technical assistance related to your installation. The charts provided should be used as a reference when building an enclosure for your **TantrumX** subwoofer.

The charts contain several enclosure types. The **Musical enclosure** provides deeper, tighter and higher quality output to provide a more accurate reproduction of the original source material. The **SPL enclosure, on the other hand**, fits the basshead's needs of maximum output while sacrificing some sound quality.

### Enclosure Recommendations

10/10d

12/12d

Sealed				Vented					Sealed				Vented				
volume ft <sup>3</sup>		volume ft <sup>3</sup>		port diameter		port length			volume ft <sup>3</sup>		volume ft <sup>3</sup>		port diameter		port length		
10	10d	10	10d	10	10d	10	10d	10	10d	12	12d	12	12d	12	12d	12	12d
.7	.7	.85	.85	2"	2"	10"	9"	Musical	1.35	1.45	2	2.1	4"	4"	13"	11.5"	
.5	.6	.85	.85	3"	3"	12"	12"	SPL	.9	.85	1.6	1.7	4"	4"	9"	7.5"	

\*The above enclosures include the driver displacement.

\*The above enclosures include the driver displacement.

### TantrumX Woofer Dimensions

	10/10d	12/12d
Mounting Depth	5 13/16 in	6 3/16 in
Mounting Diameter	9 7/32 in	11 3/16 in
Overall Diameter	10 13/32 in	12 7/8 in

## LED Instructions

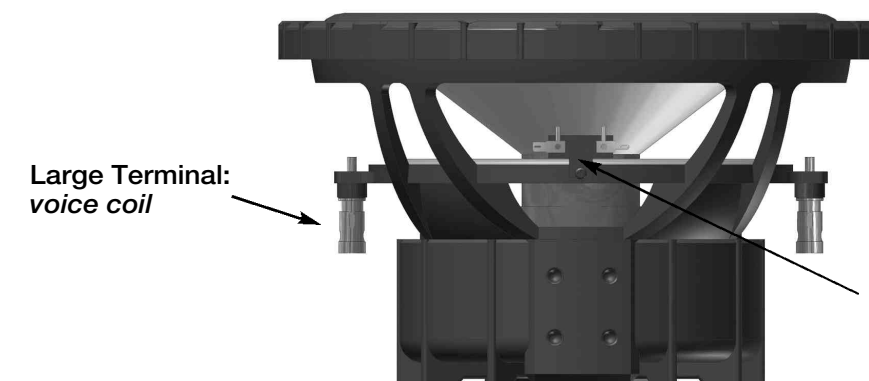

Small Terminal: LED power

+ = Switched 12 Volt Power  
- = Ground