



PHOENIXGOLD™

MONOBLOCK AMPLIFIER
OWNER'S MANUAL



FOR MODELS:

RSd1200.1



Congratulations on your purchase of high quality Phoenix Gold audio electronics. At Phoenix Gold our highest concern is musical reproduction. We appreciate that you chose our product. Through years of engineering expertise, hand craftsmanship and critical testing procedures, we have created a wide range of products to give your system all the clarity and richness you deserve.

Please read your warranty and retain your receipt and original carton for possible future use.

Great product and competent installations are only one piece of the puzzle when it comes to your system. Make sure that your install is using only the best installation accessories. Phoenix Gold manufactures everything from RCA cables and speaker wire to power/ground cable and battery connectors. With proper installation and accessories your system will sound the best that it can.

For more information about Phoenix Gold electronics, speakers and accessories please visit www.phoenixgold.com



WARRANTY

LIMITED WARRANTY ELECTRONICS (USA)

Phoenix Gold warrants this product to be free of defects in materials and workmanship for a period of one (1) year from the original date of purchase. This warranty is extended to two (2) years from the original date of purchase if product is installed by an authorized Phoenix Gold reseller. The limited warranty period for factory refurbished products expires after ninety (90) days from the original date of purchase. This limited warranty applies only to purchases from authorized Phoenix Gold resellers in the United States, and is extended only to the original purchaser of this product. (See paragraph below for information regarding purchases made in other countries.)

This warranty is not transferable from the original purchaser to any other party. If service is necessary under this warranty Phoenix Gold will (at its discretion), repair or replace the defective product with new or remanufactured product at no charge. Damage caused by the following is

not covered under warranty: accident, misuse, abuse, product modification or neglect, failure to follow installation instructions, unauthorized repair attempts, misrepresentations by the seller. This warranty does not cover incidental or consequential damages and does not cover the cost of removing or reinstalling the unit(s). Cosmetic damage due to accident or normal wear and tear is not covered under warranty.

Any applicable implied warranties are limited in duration to the period of the express warranty as provided herein beginning with the date of the original purchase at retail, and no warranties, whether express or implied, shall apply to this product thereafter. Some states do not allow limitations on implied warranties, therefore these exclusions may not apply to you. This warranty gives you specific legal rights, and you may also have other rights which vary from state to state.

WARRANTY IS VOID IF THE PRODUCT'S SERIAL NUMBER HAS BEEN REMOVED OR DEFACED.

IF YOU NEED SERVICE ON YOUR PHOENIX GOLD PRODUCT:

Phoenix Gold encourages product owners to first contact their original Phoenix Gold reseller to determine whether the issue can be resolved without sending the product back to Phoenix Gold.

If a return is necessary, the reseller will contact Phoenix Gold to obtain authorization for the return. All returns require a Return Authorization number from Phoenix Gold before shipping the product to Phoenix Gold's service facility. If a product owner is unable to return a product to the original reseller, the owner can contact Phoenix Gold directly to obtain a Return Authorization number. Units returned to Phoenix Gold without an RA number may be subject to refusal or delays.

All warranty returns should be sent to Phoenix Gold's Product Service facility freight-prepaid and must be accompanied by proof of purchase (a copy of the original sales receipt).

Non-defective items received may be returned freight-collect. Customer is responsible for shipping charges and insurance when sending the product to Phoenix Gold. Freight damage on returns is not covered under warranty.

FOR SERVICE INFORMATION IN THE U.S.A. PLEASE CALL:

Phoenix Gold Customer Service: (503) 286-9300 or (800) 950-1449 during normal business hours (8:30 AM – 5:00 PM Pacific Standard Time)

AFTER A RETURN AUTHORIZATION NUMBER HAS BEEN ISSUED, THE PRODUCT MAY BE SHIPPED TO THE FOLLOWING ADDRESS:

Phoenix Gold Product Service
9269 N. Bradford St. Portland, OR 97203

PHOENIX GOLD INTERNATIONAL, INC

9300 North Decatur St. Portland, OR 97203
(do not send product for repair to this address)

INTERNATIONAL WARRANTIES:

Products purchased outside the United States of America are covered only by that country's Authorized Phoenix Gold reseller and not by Phoenix Gold International, Inc. Consumers needing service or warranty information for these products must contact that country's reseller for information.

<p>Use the following area record basic information about your purchase.</p> <p>Model Number _____</p> <p>Serial Number (if available) _____</p> <p>Date of Purchase _____</p> <p>Store/Reseller Purchased from _____</p>





SPECIFICATIONS:

RSd 1200.1
MONOBLOCK CLASS D POWER AMPLIFIER

CEA-2006 Compliant Amplifier Power Standard

Power Output	780W RMS @ 4 ohms and $\leq 1\%$ THD+N
Signal to Noise Ratio	79 dBA (reference: 1W output @ 4 ohms)
Additional Power Output	1000W RMS @ 2 ohms and $\leq 1\%$ THD+N
Frequency Response	10Hz to 293Hz
Effective Damping Factor	6.343 @ 4 ohms
Maximum Input	9V at clipping
Maximum Sensitivity	200mV at clipping



Ratings other than CEA-2006

Power Output	1200W RMS @ 2 Ohms, 100Hz and $\leq 1\%$ THD+N
Bass Boost	+18dB @ 45Hz
Low Pass Filter Frequency Response	32 to 293Hz Lowpass, 18dB per octave
Subsonic Filter Frequency Response	5 to 55Hz Highpass, 18dB per octave
Dimensions (L x W x H):	19 ¹ / ₄ " x 11 ³ / ₁₆ " x 2 ³ / ₈ "

Due to continual product improvement, all specifications subject to change without notice.

FEATURES:

BUILT-IN ELECTRONIC CROSSOVER

18dB per octave electronic crossover for low-pass and an 18dB per octave subsonic filter.

ON BOARD PROTECTION

The on-board protection circuitry monitors abnormal conditions such as voltage spikes, short circuit and over thermal limits. When any of these conditions exist, the protection circuit will shut down the amplifier and light up the protection indicator to identify that a problem exists. Once the problem is resolved, the amplifier will return to normal operation automatically.

HIGH SPEED HIGH CURRENT MOSFET SWITCHING POWER SUPPLY

High current MOSFET transistors are used in the power supply section to minimize internal heat and maximize reliability.

HIGH CURRENT/HIGH VOLTAGE FULLY COMPLEMENTARY OUTPUT STAGE

Complementary output stage audio circuitry has been a standard in high end home amplifier design. Phoenix Gold is one of the very few car audio manufacturers to incorporate this design approach into a mobile audio amplifier.

LINE OUTPUTS

The amplifiers full-range line outputs can be used to feed signals to another amplifier for future expansion or for setting up a more sophisticated system.

WIDE RANGE INPUT SENSITIVITY ADJUSTMENT

The input sensitivity level of this amplifier can be easily varied from as low as 200 mV to as high as 8.0 volts by adjusting the control on the Input Panel.

MULTI-FUNCTION PROTECTION INDICATOR

When the red protect indicator lights up it signifies a high operating temperature is detected and the amplifier is temporarily shut down to allow for a cooling period. As soon as the temperature returns to a safe level, the amplifier will restart and resume normal operation. This indicator also lights up when the amplifier detects either an over-current situation, shorted speaker outputs or a DC offset at the outputs. Turn off the amplifier; double-check all inputs and speaker connections to make sure there is no short or inappropriate input. If all connections are in order, turn on the amplifier to resume operation.

VARIABLE BASS BOOST

The bass boost will increase the output centered at 45Hz from 0 to 18dB



CONTROLS, INDICATORS, AND TERMINALS:

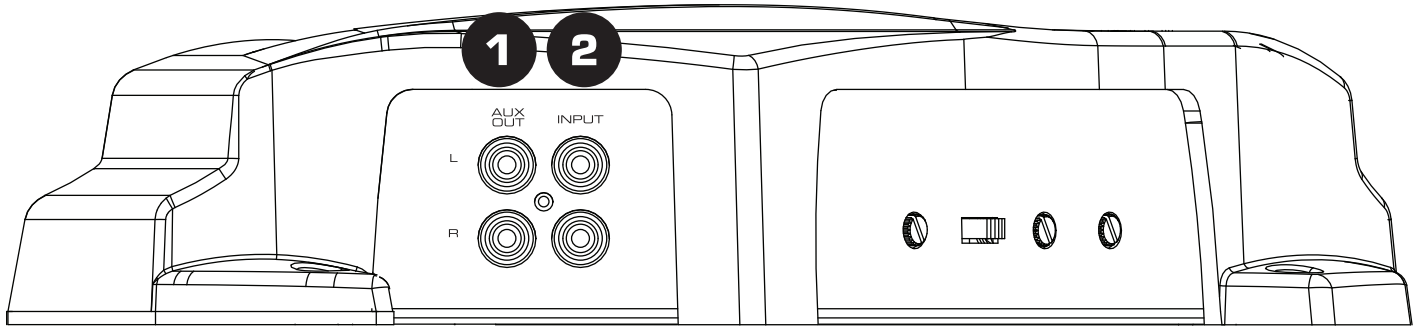

RCA INPUT

1. AUX OUTPUT (RCA)

This output is full range and can be used to connect to another amplifier for system expansion.

2. LINE LEVEL INPUT (RCA)

To be connected to RCA pre-amp outputs from a source unit (i.e., radio, tape deck or CD player).

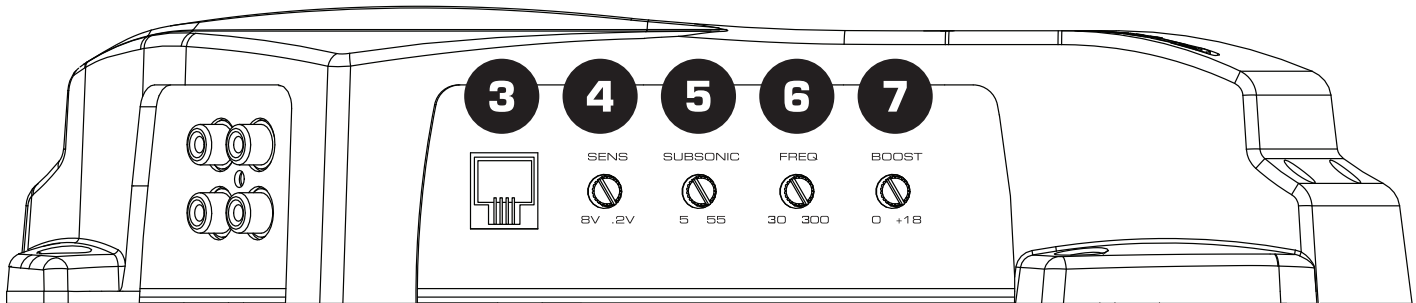

CONTROLS

3. REMOTE LOW PASS LEVEL CONTROL (LPL - SOLD SEPERATELY)

This port is for connecting the optional LPL Remote Lowpass Level Control knob allowing up to 20dB of volume adjustment.

4. INPUT SENSITIVITY LEVEL CONTROL (SENS)

The input sensitivity level can be varied from 200 mV to 8.0 volts depending on the output voltage of the source unit (refer to sub-section titled INPUT SENSITIVITY ADJUSTMENT).

5. SUBSONIC FILTER (SUBSONIC)

This is a filter to remove unwanted low frequencies that may cause damage to the speaker or are inaudible. When this is used properly it will allow the amplifier to run more effectively.

6. FREQUENCY SELECTOR (FREQ)

Allows variable adjustment from 30 to 300Hz

7. VARIABLE BASS BOOST (BOOST)

The bass boost will increase the output centered at 45Hz from 0 to 18dB

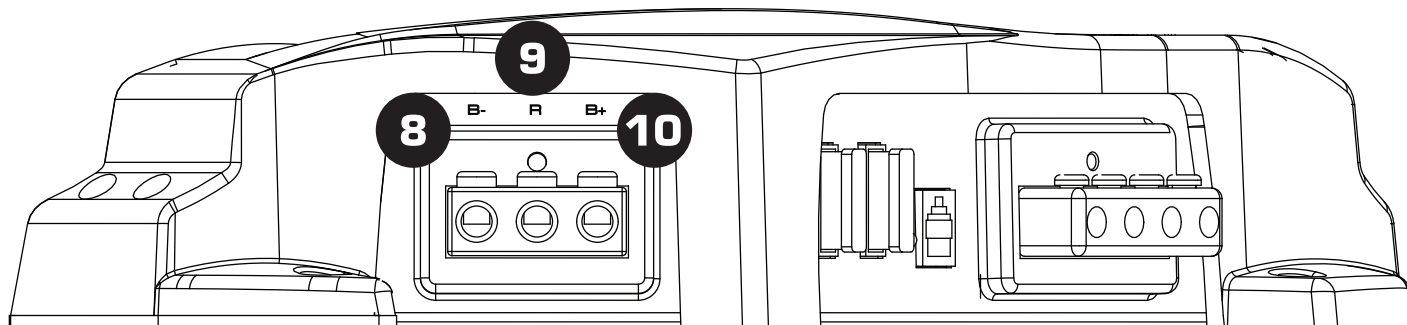

POWER INPUT

8. GROUND INPUT TERMINAL (B-)

To be wired to the vehicle's chassis for ground.

9. REMOTE TURN-ON INPUT TERMINAL (R)

To be connected to the remote control wire or power antenna lead of the source unit for remote ON/OFF.

10. POWER INPUT TERMINAL (B+)

To be connected to the positive terminal of the vehicle's battery or other constant +12 V source. Remember to fuse at 12+ source.

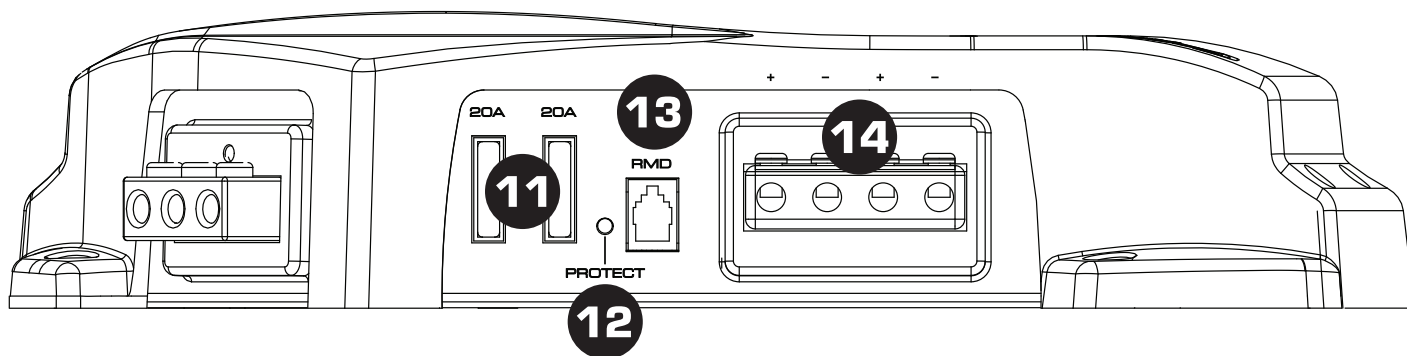

SPEAKER OUTPUT AND FUSING

11. AMP FUSE

Protects the amplifier. If a replacement is necessary, use the same size and type indicated on the end panel. Never use a fuse with a higher amp rating.

12. PROTECT LED

Red light: Amplifier is in protection - Overheated (will resume play on its own), Low voltage, Shorted terminal

No light: Amplifier is functional (when power is on)

Note: "Power On" is indicated when the badge/logo on top of the amplifier lights up blue

13. RMD PORT (RMD - SOLD SEPERATELY)

This connection allows for connection of our remote voltage display (optional), so that you can monitor the applied voltage at the amplifier in real time.

14. SPEAKER OUTPUT TERMINAL

Used to connect the amplifier to speakers. The recommended speaker wire size 12 gauge.

INSTALLATION

Note: Verify that your vehicle does not have a positive ground electrical system, this is very rare. A positive ground system is the reverse of most standard vehicles in that the + battery terminal is connected to the vehicle chassis and is typically found in some older European vehicles. If you have any questions do not proceed until you have verified this. If it is a positive ground electrical system please contact your dealer for assistance.

Caution: Please follow all the installation recommendations and instructions in this manual. Installation in any manner not outlined in the manual will void your warranty and may possibly cause damage to the vehicle and/or the amplifier.

Warning: The battery ground should remain DISCONNECTED at all stages of installation.

LOCATION/MOUNTING

When selecting a location to mount your amplifier, please keep in mind that electronics are sensitive to vibration, moisture, and heat. Make sure the amplifier is mounted in an area with ample ventilation and is not exposed to moisture or external heat. For proper cooling, it is recommended to mount the amplifier horizontal or vertical but not upside-down. Automobiles have a certain level of normal vibration and we have designed the product with this in mind, but excessive vibration may cause damage over time. Using the amplifier for a template, mark the mounting holes in your selected area while following the preceding guidelines. Verify that you are not going to damage sensitive vehicle systems by drilling where you have selected (look for gas tank, wires, etc...). Remove the amplifier and pre-drill the locations for the size screws/bolts that you have selected that fit the amplifier and your installation purposes. Permanently mount the amplifier to selected location.

Figure 3. Typical System connection

Note: It is best to mount the amplifier to some form of insulating surface, such as MDF, so that the chassis of the amplifier does not come in contact with the vehicle chassis (if a single screw makes contact with both the amplifier and vehicle chassis, it is the same as no insulator). This will lessen the possibility of any ground related noises and will shield minor amounts of radiated noise.

Figure 3. Typical System Connection

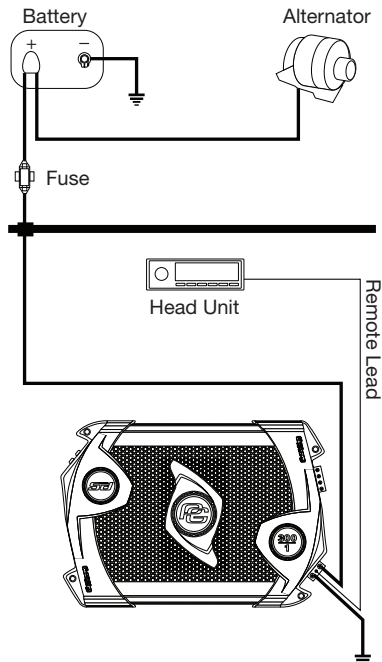

INPUT CONNECTIONS

Connect RCA input jacks of the Amplifier to the output of the Source Unit (i.e. Radio, Cassette player or CD player).

SPEAKER CONNECTIONS

When connecting the Amplifier to the Speaker, use heavy gauge speaker cable for these connections (12AWG recommended minimum).

We recommend that the minimum total impedance of the speaker load is no less than 2 ohm. The amplifier has 2 each (+) terminals and 2 each (-) terminals. These terminals are duplicates, meaning you can use any combination of + and - connections for a single speaker. Connect the positive (+) speaker output of the amplifier to the positive (+) terminal of the speaker. Connect the negative (-) speaker output of the amplifier to the negative (-) terminal of the speaker.

Figure 4: Single Woofer Connection

CAUTION: ANY DEVIATION FROM THE ABOVE SPEAKER CONNECTION MAY CAUSE SERIOUS DAMAGE TO THE AMPLIFIER AND/OR SPEAKERS. PLEASE DOUBLE CHECK THE CONNECTION BEFORE TURNING THE SYSTEM ON.

Figure 4: Single Woofer Connection

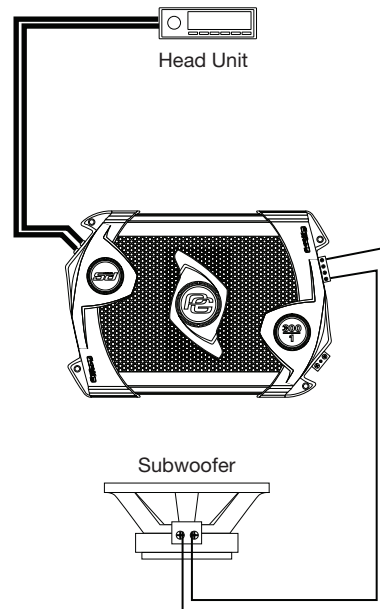

ADJUSTMENTS

CROSSOVER FREQUENCY SELECTION

Fully variable crossover from 30 to 300Hz. Adjust this setting according to your speakers specification or to your particular preference.

Figure 5: Crossover and Frequency Selection

INPUT SENSITIVITY ADJUSTMENT

The Input Sensitivity Control is located on the Input Panel. The objective of the input sensitivity adjustment is to match the output of the source unit with the input of the amplifier (it is not a volume control). The output voltage of individual source units can vary. For example, some source units have an output of 200 mV others have 4 Volts or more. Adjusting this control requires some experimenting. Basically you want all the gain at the beginning of the system, NOT at the end (amplifier). Turn your source unit volume UP and keep your amplifier gains at the minimum possible settings. This will give you the best sound and signal-to-noise ratio.

Figure 6: Input Sensitivity Control

NOTE: Turning the input gain up does not indicate more power, but increases the possibility of noise. The input gain control is not a volume control. The function of the gain is to match the voltage that the amplifier is looking for, to the voltage that the source unit is supplying

1. Turn the Input Sensitivity Control all the way down (counter clockwise).
2. Set the volume control of the source unit to approximately 3/4 of its maximum output.
3. Turn the balance control of the source unit to its center position.
4. Set the tone (bass/treble) controls to flat (zero).
5. Play a song (original recording) with wide dynamic range
6. To locate the optimum input sensitivity setting, turn the Input Sensitivity Control clockwise until audio distortion starts to develop. Turn the sensitivity control counter clockwise slightly until you no longer hear distortion.
7. If you constantly switch between sources (CD/tape and radio), you will need further adjustment since radio output level differs from that of CD or tape. In this case, you need to locate a balanced sensitivity setting which is best for both the output level of radio and that of CD or tape.

Figure 5: Crossover Frequency Selection



Both the high-pass and the low-pass section offer a fully variable crossover from 30 to 300Hz. Adjust this setting according to your speaker component specifications or to your particular preference.

CONNECTING AMPLIFIER POWER WIRE TO THE BATTERY (B+)

Power cables are as important as battery capacity. Use no less than an 8AWG (8 gauge) power cable, while 4 gauge would be optimum for most applications. **YOU CAN NEVER HAVE TOO BIG OF A POWER/GROUND WIRE!** Run the power cable through the interior of the vehicle (Avoid moving parts: seat rails, steering column, etc...) connecting one end to the amplifiers (+) terminal and connecting the other end to a proper sized fuse link within 18 inches of the positive post on the battery. If possible do not run the power cable together with the audio cables as it could possibly cause radiated noise in your audio system. It is recommended to run audio cables on one side of your car and power cables on the other.

Total RMS Power	Recommended Cable Size				
	Distance				
	4 ft.	8 ft.	12 ft.	16 ft.	20 ft.
100W	8 ga.	8 ga.	8 ga.	8 ga.	4 ga.
200W	8 ga.	8 ga.	8 ga.	4 ga.	4 ga.
400W	8 ga.	8 ga.	4 ga.	4 ga.	4 ga.
600W	8 ga.	4 ga.	4 ga.	4 ga.	4 ga.
800W	4 ga.	4 ga.	4 ga.	2 ga.	2 ga.
1000W	4 ga.	4 ga.	2 ga.	2 ga.	2 ga.
1400W	4 ga.	2 ga.	2 ga.	2 ga.	1/0 ga.

Note: The proper size primary fuse/circuit breaker (located within 18 inches of the battery) may vary depending on your system design but should not exceed 50% of the main batteries' amp hour rating. Using a larger value circuit breaker or fuse value means that you have NO protection. DO NOT over fuse! Fuses on the amplifier and at the battery DO NOT protect the amplifier, they protect the car.

CONNECTING AMPLIFIER GROUND WIRE (B-)

It is recommended to run a ground wire directly to the battery as you would do with the positive cable, to avoid any voltage losses and possible ground related noises. You can use the vehicle chassis, and if you chose to do this find a solid ground point (Frame, Strut Tower, Reinforced area near seat/seatbelt) and remove the paint to reveal bare metal. Attach the ground wire to the chosen ground source and connect the other end of the ground wire to the GND terminal of the amplifier.

Note: The ground wire should be the same gauge cable as the power cable running from the positive post of the battery to the amplifier.

TERMINALS AND CONNECTORS

Proper size terminals and/or connectors are required to ensure a safe and secure electrical connection and conduction.

CONNECT THE AMPLIFIER REMOTE LEAD (R)

Connect the remote "R" terminal of the amplifier to the remote output lead of the source unit so that the amplifier will turn on and off with the source unit. If the source unit does not provide a remote output, connect to the source units' switched 12+ volt source.

RECONNECT THE BATTERY GROUND TO THE VEHICLE CHASSIS

Double check all the previous installation steps, in particular, the wiring and component connection. If everything is in order, complete the installation by reconnecting the battery ground to the vehicle chassis.

Figure 6: Input Sensitivity Control

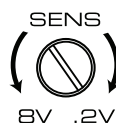

The Input Sensitivity Control is located on the Input Panel. The objective of the input sensitivity adjustment is to match the output of the source unit with the input of the amplifier (it is not a volume control). The output voltage of individual source units can vary.



TROUBLE-SHOOTING

SYMPTOM: POSSIBLE CAUSE

No power: Check voltage at amplifier with a DMM (volt meter), B+ and REM (with source unit on) the voltage should register between 12.2V-14.6V when using the attached ground lead of the amplifier. Check fuse at amplifier and at the battery. Use a meter to verify connection from one end of the fuse to the other, breaks may not always be visible. If fuse is blown, check the power wire and also the amplifier for a short. If the short is in the power wire, repair it. If the short is in the amplifier itself, see your Phoenix Gold dealer. If no short is present replace the fuse.

Power without sound: Turn the amplifier off and check all input and output signal cables and power connections. Check the speakers for shorts with a DMM (volt meter) or by connecting them to another audio source. After making sure everything is normal, turn the amplifier on again.

Power without sound and status LED is lit red: The continuous red light of the power indicator signals a high internal operating temperature, which results in the amplifier switching off temporarily. When the amplifier cools down to a safe level, the amp will automatically restart. The continuous red light of the power indicator can also indicate a shorted speaker lead or battery voltage that is either too high or too low for proper operation.

No sound from one side: Check balance control. Check speaker connections. Check signal input connection.

Very low output: Check your source unit's fader control. Check the amplifier's Input Sensitivity Level.

Frequent automatic amplifier shut down: This indicates that the amplifier is operating at a continually undesirable high internal temperature. High operating temperature can be caused by inadequate ventilation: Refer to the sub-section titled LOCATION for better amplifier location. High operating temperature can also be caused by an excessively low impedance load. For instance below 2 ohms stereo or 4 ohms bridged. Check for bad speakers or bad passive crossover components. If all else fails, try rewiring the entire system. High operating temperature can be caused by an incorrect input sensitivity level, refer to sub-section titled INPUT SENSITIVITY ADJUSTMENT.

"Motor Boating" - the power indicator going off repeatedly when the audio system is on: Check the amplifier's connection to the battery. Check battery voltage. If low, recharge or replace battery. Check all ground connections.

Whining noise when engine is running: Reroute power cable from battery to source unit directly (include fuse), bypassing the battery terminal in the fuse box. Check power connections to be sure they are clean. Check the battery ground making sure the battery terminals and chassis ground are clean. Run a ground wire from the source unit to the ground point of the amplifier and remove old source ground.

CAUTION: Do not disconnect the Power Amplifier's ground when the system is on. This could damage the amplifier.

