

ZEROpoint ZCS641 Component System

The ZCS641 is the combination of the ZCS4 component set and a pair of ZPM160 6.5" speakers. The computer optimized network shown below was designed in conjunction with the average vehicle's transfer function. This system will result in a full range system with unparalleled dynamic range and accuracy. Due to the constraints of mounting the ZPM160's "near" the ZPM100's, it may be necessary to invert the polarity of the ZPM160's for optimum results!

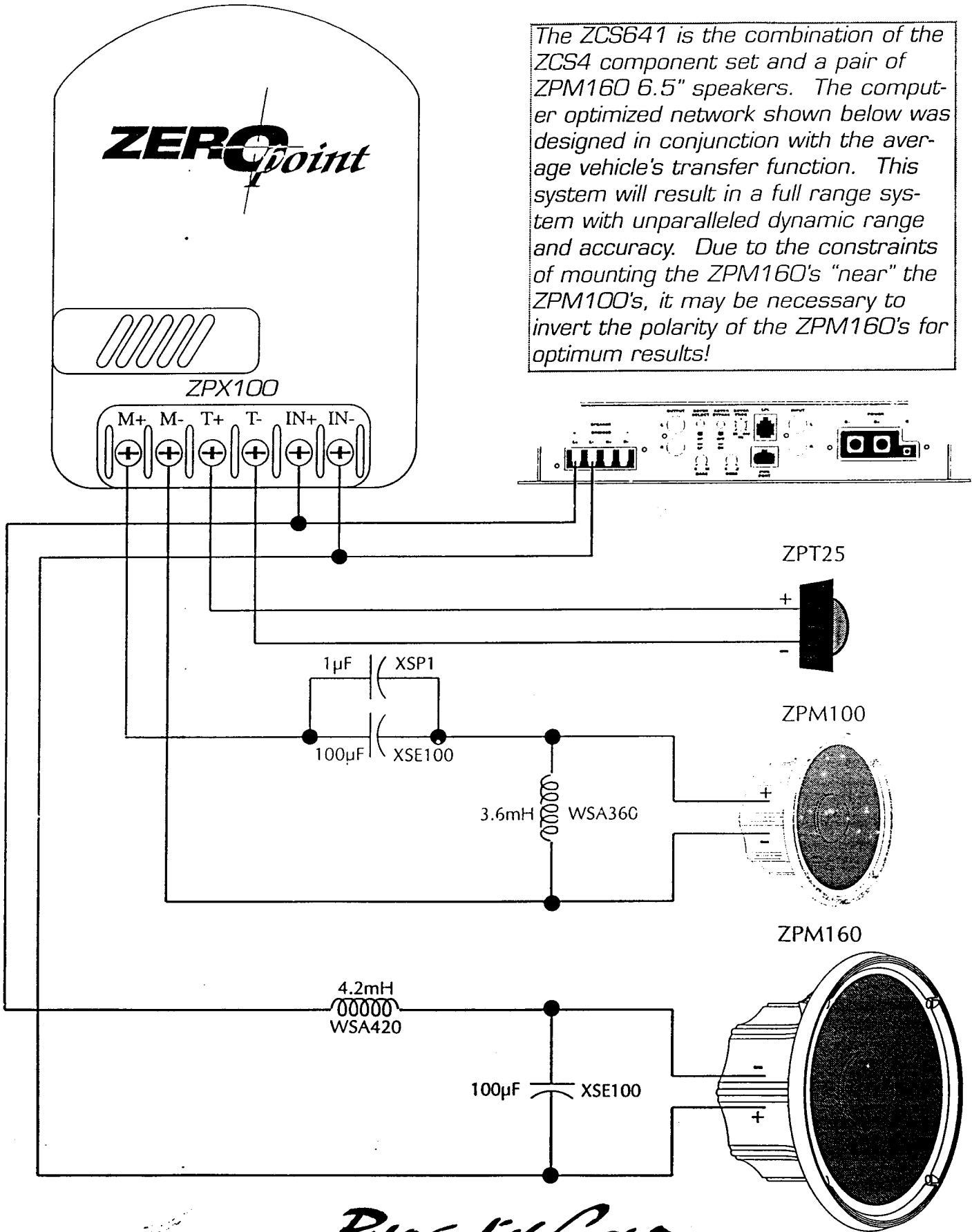

PHOENIX GOLD
ACOUSTICS

ZCS4 --> ZCS642 X-OVER MODIFICATION

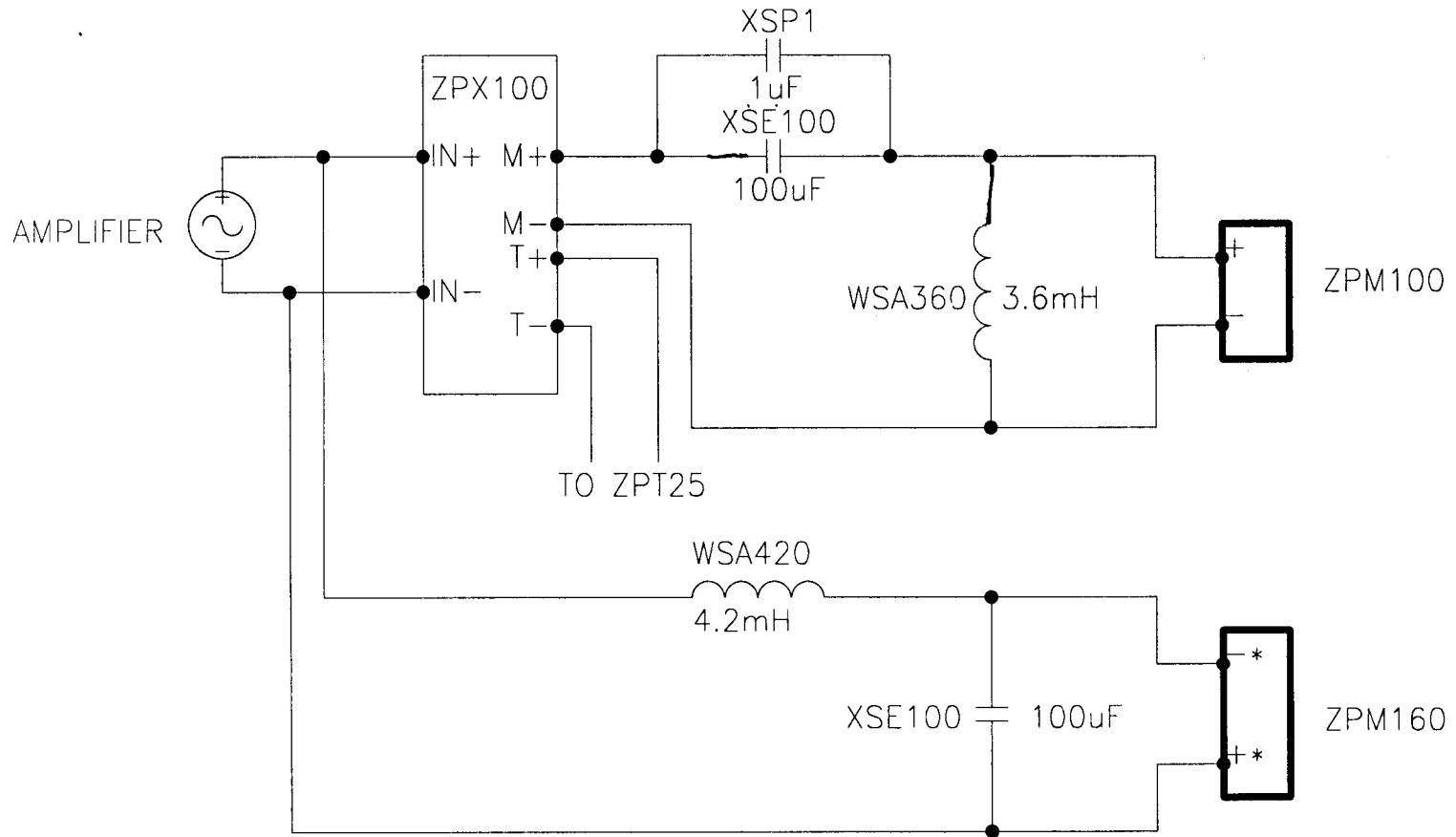

* Experiment w/phase on ZPM160 for proper response.